

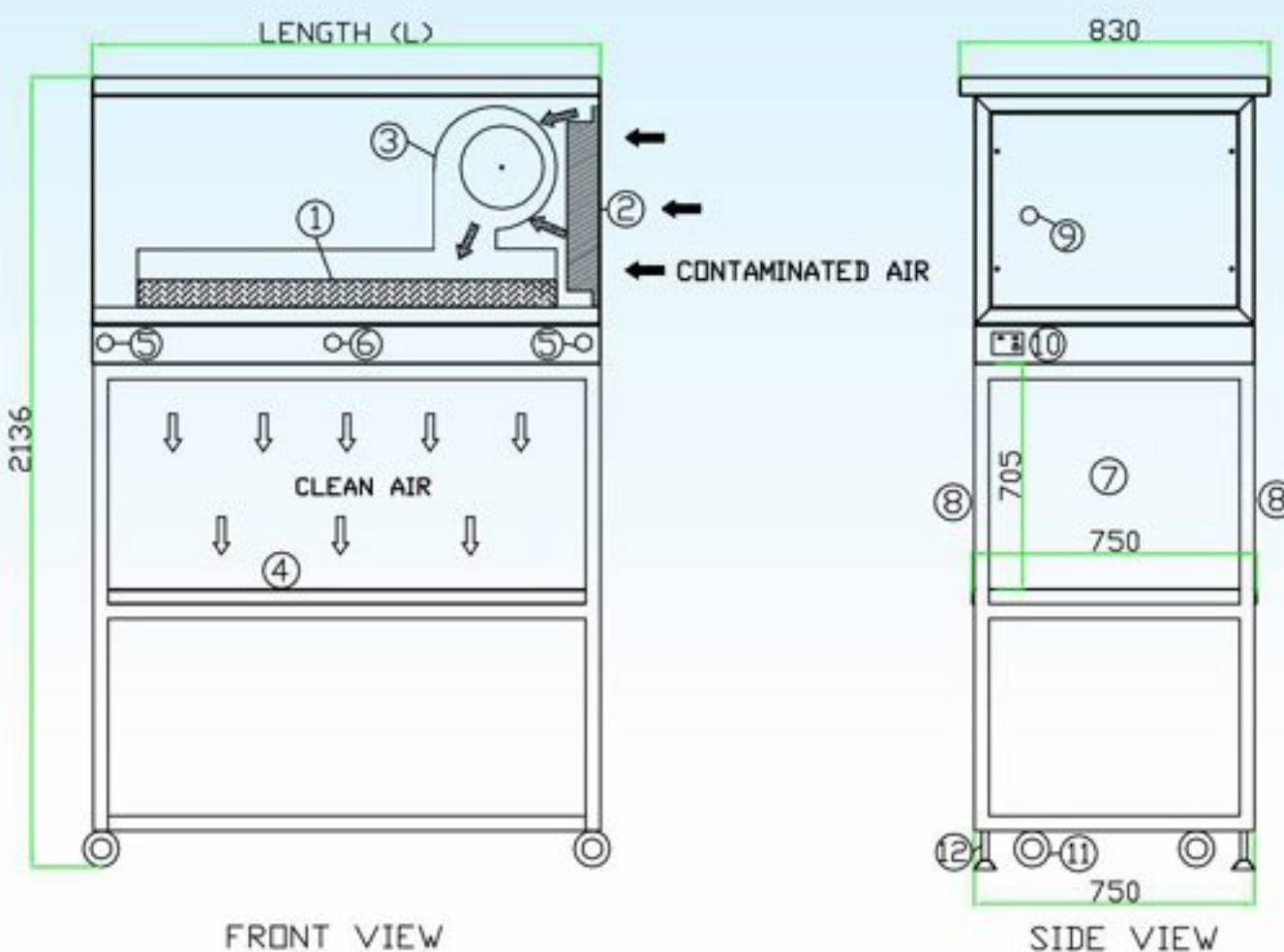

### Working & Features of Vertical Laminar Flow unit

The Vertical Laminar airflow provides product protection within the work area, which is confined by clear glass panels and sliding glass doors.

- Room air is taken in from the side of the cabinet through a pre-filter with 90% efficiency which traps particles of  $10\mu$  and above.
- Air is spread evenly across the HEPA filter, thereby providing a stream of clean air within the work area of the cabinet; this removes all contaminated air from the interior.
- Perforated Stainless Steel diffuser screen protects the HEPA filter and maintains uniform air flow velocity within the work area.
- Vertical Laminar Flow occupies less space and can be installed in a small area.
- Provides extra workspace ( Depth of 29.5" / 750 mm)
- Advantage of working from both the sides and visibility from all sides.



No.	Description
1	Hepa Filter
2	Pre- Filter
3	Motor Blower Assembly
4	Work Table
5	Tubelights
6	Ultra Violet Tube
7	Side Glass
8	Front Glass Door
9	Minihelic Gauge
10	Electronic Switch
11	Movable PU Wheels
12	Levelling Lugs



Name of the Equipment	VERTICAL FLOW MODEL				
Model	MFI V 2X2	MFI V 3X2	MFI V 4X2	MFI V 6X2	
External Dimensions (LXWXH) in Inches & MM	29.5"X 29.5" X 84" 750 X 750 X 2136	41"X 29.5"X 84" 1050 X 750 X 2136	53.5"X 29.5"X 84" 1360 X 750 X 2136	77.3"X 29.5"X 84" 1965 X 750 X 2136	
Work Area Dimensions (LXWXH) in Inches & MM	26.3"X 29.5"X 27.75" 670 X 750 X 705	26.3"X 29.5"X 27.75" 970 X 750 X 705	26.3"X 29.5"X 27.75" 1280 X 750 X 705	26.3"X 29.5"X27.75" 1885 X 750 X 705	
Material of Construction	Galvanized Iron Sheet with Epoxy Polyester Thermosetting Powder Coating of 80 microns, 1.5 mm Thickness / Stainless Steel grade 304, 1.2 mm Thickness for SS Models.				
Body Finish	Glossy Off White Colour for GI Powder Coated / Matt grit finish for Stainless Steel 304				
Table Top	1.2 mm SS 304 sheet of Matt Finish pressed on 25mm Solid Nuwud Board				
Side Glass	5 mm Float Glass encased in powder coated channels.				
Front Door	Frameless Sliding Glass Doors of Toughened glass 6 mm thickness - 2 nos.				
Wheels & Leveling Lugs	PU solid wheels with plated brackets & Metallic Powder Coated Leveling Lugs for GI Model PU solid wheels with SS 304 Brackets & Solid SS 304 Leveling Lugs For S.S. Models.				
Design & Classification	Visibility from all four sides with advantage of both sides working. Side Loading Pre-Filters. Complete work area will be of SS 304 including HEPA Grill .Unit mounted on square tubular pipe structure for GI / SS 304 models. As per IEST - RP - CC002.2 (Institute of Environmental Sciences and Technology - Recommended Practice -CC002.2)				
Cleanliness Class	ISO Standard 14644 - 1 -Class 5				
Stages Of Filtration	1) Pre-Filters = 10µ with an efficiency of 90% Washable HDPE media in FRP PU Coated Frame for GI models. For SS 304 models the frame will be in SS 304 2) Mini pleat HEPA Filter Encased in Aluminum Frame Final = 0.3µ with an efficiency of 99.995% (Anti-Microbial treated media) (HEPA Media : Made in Italy) *ULPA filters available on request				
Motor Blower Assembly	"Godrej" make variable speed motor mounted on PU coated FRP Blowers with Aluminum Powder Coated Impellers				
Velocity	100 FPM at 6" from face of the filter				
Noise Level	< 60 Db at 1 Meter from the face of the equipment				
Pressure Gauge	Dwyer (U.S.A) make Minihelic gauge.				
HEPA Filter Grill	SS 304 grill duly perforated and polished				
Electrical	Switches & Speed Controller	Microprocessor Controlled Feather Touch switch panel			
	Fluorescent lighting	18 Watt - 2 nos.	18 Watt - 2 nos.	18Watt - 2 nos. 36 Watt - 1 no.	18Watt - 3 nos. 36 Watt - 1 no.
	Chokes for lighting	18 watts - 3 nos.	18 watts - 4 nos.	18Watt - 2 nos. 36 Watt - 1 no.	18Watt - 3 nos. 36 Watt - 1 no.
	Ultra Violet Lighting	1.5 feet length G15T8 15 Watt - Philips	1.5 feet length G15T8 15 Watt - Philips	3 feet length G30T8 30 Watt - Philips	3 feet length G30T8 30 Watt - Philips
	Power Consumption	230 Watts	250 Watts	280 Watts	535 Watts
	Lighting	> than 800 lux			
	Power Supply	Single phase 5 Amps power cord, 230V, 50Hz power supply, For Model MFI V 6x2 15 Amps power cord			
Accessories	Gas / Vacuum Cock	Standard make - Optional			
	Gas Burner	Standard make - Optional			