

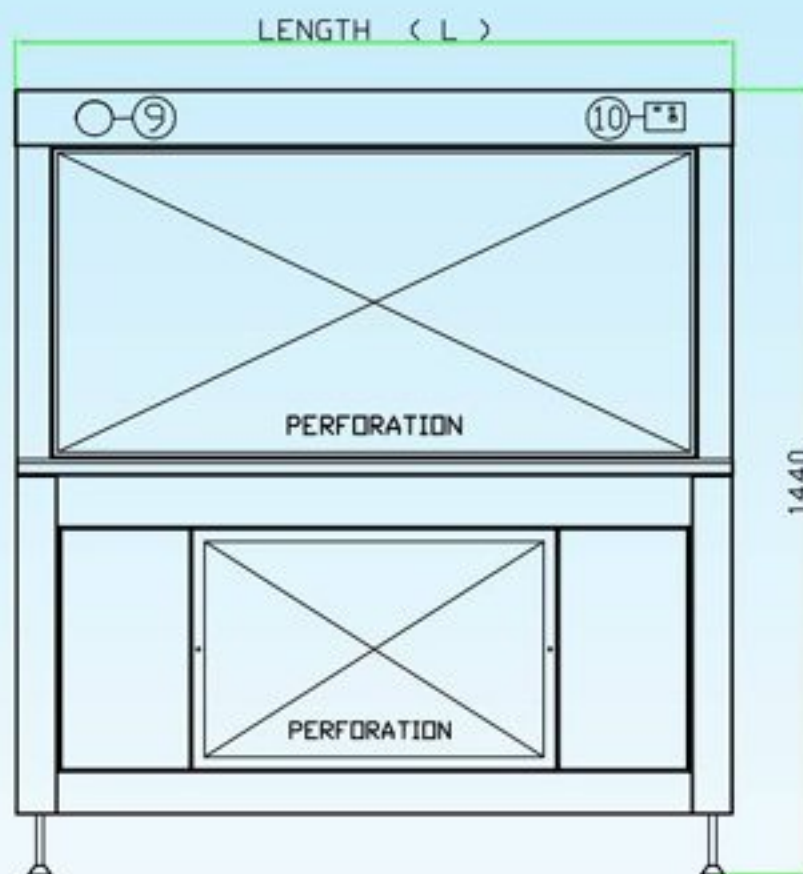

Working & Features of Horizontal Laminar Flow unit

The Horizontal Laminar airflow provides product protection within the work area, which is confined by removable clear glass panels and polycarbonate shutter.

- Room air is taken in from the bottom of the cabinet through a pre-filter with 90% efficiency which traps particles of 10μ and above.
- Air is spread evenly across the HEPA filter, thereby providing a stream of clean air within the work area of the cabinet; this removes all contaminated air from the interior.
- Perforated Stainless Steel diffuser screen protects the HEPA filter and maintains uniform air flow velocity within the work area.
- Easy disassembly for access through a small door.
- Front angular 10 degree slope helps reduce operator fatigue while working on the cabinet.



FRONT VIEW



SIDE VIEW

No.	Description
1	Hepa Filter
2	Pre- Filter
3	Motor Blower Assembly
4	Work Table
5	Tubelights
6	Ultra Violet Tube
7	Side Glass

No.	Description
8	Polycarbonate front door
9	Minihelic Gauge
10	Electronic Switch
11	5/15 Amps Plug Point
12	Movable Wheels
13	Levelling Lugs

Name of the Equipment	HORIZONTAL LAMINAR FLOW				
Model	MFI H 2X2	MFI H 3X2	MFI H 4X2	MFI H 6X2	
External Dimensions (LXWXH) in Inches & MM	27.75"X 34.25"X 56.7" 705 x 870 x 1440	40"X 34.25"X 56.7" 1020 X 870 X 1440	51.75"X 34.25"X 56.7" 1315 X 870 X 1440	76"X 34.25"X 56.7" 1930 X 870 X 1440	
Work Area Dimensions (LXWXH) in Inches & MM	22.5"X 24"X 22.52" 572 X 610 X 572	34.45"X 24"X 22.52" 857 X 610 X 572	46.45"X 24"X 22.52" 1180 X 610 X 572	70.5"X 24"X 22.52" 1790 X 610 X 572	
Material of Construction	Galvanized Iron Sheet with Epoxy Polyester Thermosetting Powder Coating of 80 microns, 1.5 mm Thickness / Stainless Steel grade 304 1.2 mm Thickness for SS Models.				
Body Finish	Glossy Off White Colour for GI Powder Coated / Matt grit finish for Stainless Steel 304				
Table Top	1.2 mm SS 304 sheet of Matt Finish pressed on 25mm Solid Nuwud Board				
Side Glass	6 mm Float Glass encased in Stainless Steel Channels.				
Front Door	Frameless Gas Spring loaded swinging type Polycarbonate 6 mm thickness				
Wheels & Leveling Lugs	PU solid wheels with plated brackets & Metallic Powder Coated Leveling Lugs for GI Model PU solid wheels with SS 304 Brackets & Solid SS 304 Leveling Lugs For S.S. Models.				
Design & Classification	Front Bottom Loading Pre-Filters / Complete work area will be of SS 304 including HEPA Grill, Table Top and Light Canopy Internal surface for GI models and SS models / Angled front slope of 10 degrees to reduce operator fatigue while working. As per IEST - RP - CC002.2 (Institute of Environmental Sciences and Technology - Recommended Practice -CC002.2)				
Cleanliness Class	ISO Standard 14644 - 1 -Class 5				
Stages Of Filtration	1) Pre-Filters = 10µ with an efficiency of 90% Washable HDPE media in FRP PU Coated Frame for GI models. For SS 304 models the frame will be in SS 304 2) Mini pleat HEPA Filter Encased in Aluminum Frame Final = 0.3µ with an efficiency of 99.995% (Anti-Microbial treated media) (HEPA Media : Made in Italy) *ULPA filters available on request				
Motor Blower Assembly	"Godrej" make variable speed motor mounted on PU coated FRP Blowers with Aluminum Powder Coated Impellers				
Velocity	100 FPM at 6" from face of the filter				
Noise Level	< 60 Db at 1 Meter from the face of the equipment				
Pressure Gauge	Dwyer make Minihelic gauge. Made in U.S.A				
HEPA Filter Grill	SS 304 grills duly perforated and polished				
Electrical	Switches & Speed Controller	Microprocessor Controlled Feather Touch switch panel			
	Fluorescent lighting	18 Watt - 2 nos.	18 Watt - 3 nos.	36 Watt - 2 nos.	36 Watt - 4 no.
	Chokes for lighting	18 watts - 3 nos.	18 watts - 4 nos.	36 Watt - 3 no.	36 Watt - 5 nos
	Ultra Violet Lighting	1.5 feet length G15T8 15 Watt - Philips	1.5 feet length G15T8 15 Watt - Philips	3 feet length G30T8 30 Watt - Philips	3 feet length G30T8 30 Watt - Philips
	Power Consumption	230 Watts	250 Watts	280 Watts	535 Watts
	Lighting	> than 800 lux			
	Power Supply	Single phase 5 Amps power cord, 230V, 50Hz power supply, For Model MFI H 6x2 15 Amps power cord			
Accessories	Gas / Vacuum Cock	Standard make - Optional			
	Gas Burner	Standard make - Optional			